

STORING WATER IN SOIL FOR LANDSCAPE TREES IN ARID CLIMATES

by J. Alan Wagar

Demand for water in such arid climates as southern California and the Southwest is growing and pressing hard upon available supplies. As competition for water increases, regular watering of landscape trees may become increasingly expensive, and some observers foresee complete prohibition of watering during droughts (Frank Simerly, formerly Assistant Director, Los Angeles County Department of Arboreta and Botanic Gardens and currently Horticultural Director, City of Hope National Medical Center, Duarte, California, personal communication, fall 1979). Yet, in urban areas, a substantial part of available precipitation lands on roofs and other impervious surfaces and is quickly carried away in runoff channels, often causing erosion and flooding downstream.

To test the usefulness of storing runoff in the soil for later use, a study was conducted in the Central Valley of California approximately 15 miles west-southwest of Modesto next to Interstate Highway 5 (fig. 1). This site is at least as stressful to vegetation as the Los Angeles Basin and has an average annual precipitation of approximately 11 inches, nearly all of which falls from September through May. Summertime temperatures are commonly over 100°F and are often accompanied by strong winds. Winters are generally mild, with temperatures occasionally dropping a few degrees below freezing. Soil at the site is a deep gravelly clay loam.

Procedures

During fall and winter 1980, four European olive trees (*Olea europaea*) were planted on each of 12 circular plots for a total of 48 trees. Each plot was approximately 11 feet in diameter. To isolate each plot from surrounding conditions, permitting it to represent a much larger area, a trench was dug around it and a vertical wall of polyethylene plastic installed to a depth of 4 or 5 feet, after which the

trench was refilled. The plastic prevented water movement to and from the surrounding soil and kept roots of surrounding vegetation from invading the plots. To protect plots from pocket gophers and rabbits, a fence of poultry wire was established around each plot, extending 18 inches above and 18 inches below ground.

Four treatments were randomly assigned to the 12 plots, all of which were covered with a 2-inch layer of gravel to reduce evaporation. To simulate the spreading of water from roofs and pavements, six plots were provided with plywood catchment surfaces that doubled the amount of water received during each storm (fig. 2). Ramadas were installed at three of the plots with catchment surfaces and at three plots without such surfaces. Each ramada was covered with 50 percent shadecloth and positioned to shade trees between March 21 and September 23 (fig. 3). Installation of catchment surfaces and ramadas resulted in three control plots with neither catchment surfaces nor shade, three plots with shade only, three with catchment surfaces only, and three with both shade and catchment surfaces.

During summer 1981, the olive trees were watered to ensure their establishment.

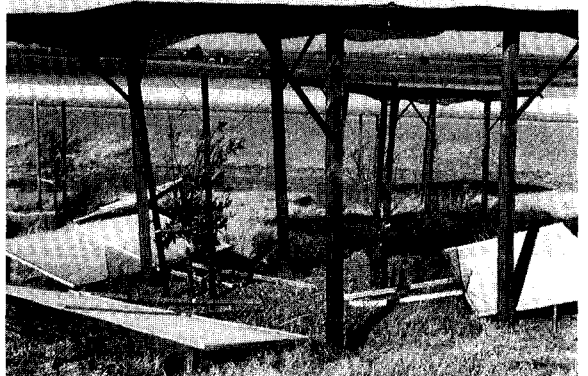

Figure 1. The study site was in the Central Valley of California approximately 15 miles west-southwest of Modesto.

Thereafter, they received no supplemental watering, the point of the experiment being to determine whether they could survive through dry summers on the water stored in the soil during winter rains.

From September 1981 through April 1982, the study site received approximately 12 inches of precipitation, based on records from the Kerlinger weather station 17 miles to the northwest. The plots received no precipitation in May. As mentioned, catchment surfaces approximately doubled the amount of moisture six of the plots received from each storm.

In early spring 1982, half the trees were removed to reduce competition for water, leaving two trees on each plot. The trunks of these remaining trees were caged with hardware cloth to protect them from mice and voles. To further reduce competition for moisture, weeds on all plots were killed with an herbicide.

To determine how well soil moisture from the prior winter would last into summer, pressure-bomb measurements were taken for all trees at 2-week intervals from 21 May to 28 September 1982. Readings were taken immediately before dawn because, during the night, there is little transpiration and moisture throughout the tree comes into approximate equilibrium with that in the roots and the soil immediately surrounding the

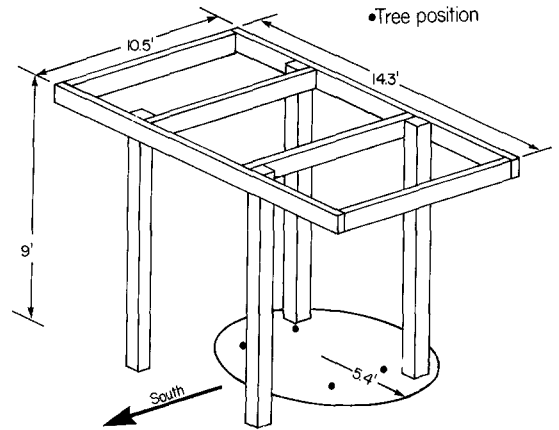

Figure 3. Ramadas covered with 50-percent shade cloth provided trees on six of the plots with partial shade between March 21 and September 23.

roots. Usually, only one reading per tree was taken during each measurement period. (Variability was such that two or more readings per tree would have been better.)

Pressure-bomb readings indicate moisture stress in plant tissue (1) which in turn indicates soil moisture depletion. When a leaf is placed in a cylindrical pressure bomb with only its petiole sticking out through a special rubber stopper, moisture status of the leaf, roots, and soil is determined by admitting compressed nitrogen into the bomb and noting at what pressure moisture is first forced from the petiole: the higher the required pressure, the drier the leaf tissue as well as the roots and soil surrounding them.

In spite of our caging stems with hardware cloth and applying poison the preceding summer, mice and voles completely girdled many of the study trees during summer 1982, digging under the hardware cloth and gnawing the bark off stems and the upper portions of root systems. All trees survived into the fall in apparently good health, but their roots were being starved and all but two trees (that escaped complete girdling) later died. Pressure-bomb measurements indicated obvious differences in moisture conditions (fig. 4), but different rates of root failure may have increased the variability among trees.

In spring 1983, all but the two olives surviving

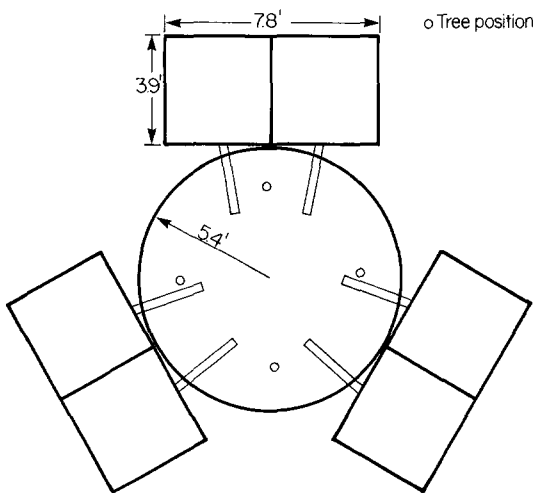

Figure 2. Plan view of plywood catchment surfaces that doubled the amount of water six of the plots received during each storm.

on one control plot were replaced with Valencia orange trees (*Citrus sinensis* 'Valencia'). This cultivar was selected as a readily available broad-leaved evergreen that is believable as a street tree and that requires considerably more water than the olives. To maintain the original study design of three plots for each of four treatments, an additional control plot with two orange trees was established. The orange trees were watered periodically during summer 1983 to aid establishment.

Pressure-bomb measurements planned for summer 1984 were not made because the trees had few leaves and existing leaves were often withered. Precipitation during the preceding September through May was somewhat below average (8.23 inches at Kerlinger weather station). During summer 1985, the trees had unusually little moisture. Rainfall was well below average—6.81 inches for the preceding September through May. (Kerlinger weather sta-

tion quit reporting after December; January through May information is from the Tracy Pumping Plant, 32 miles northwest of the study site.) Also, budget constraints precluded weed control. During late winter and spring rank growths of grass and weeds competed with trees for available moisture.

Results and Discussion

During summer 1982, pressure-bomb readings for the olive trees showed the soil moisture increasingly depleted as the season progressed (fig. 4). This depletion was alleviated only by a light rain in late June and a heavier rain that ended the dry season in mid-September. Moisture stress was considerably less among trees with catchment surfaces than those without, indicating that extra moisture can be stored in the soil for later use, a practice long used in dryland farming.

The role of shade was less clear. Shading appeared to offer some advantage for trees without catchment surfaces, possibly by reducing

Soil Storage of Water

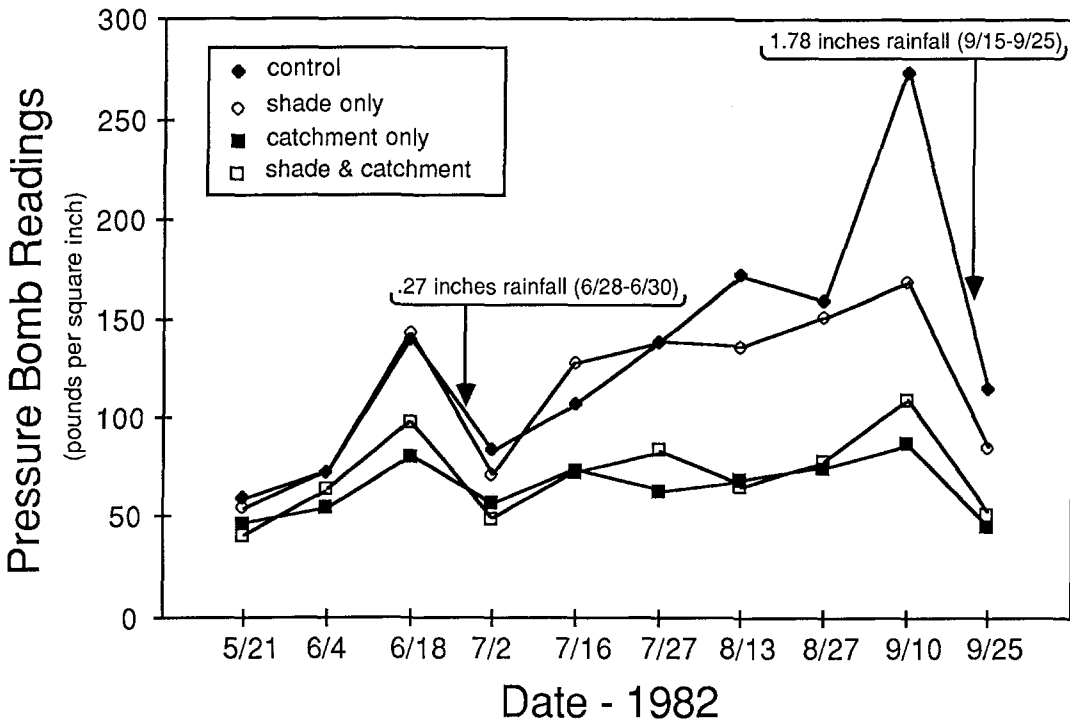

Figure 4. Soil moisture depletion as indicated by pressure-bomb readings of European olive trees, summer 1982.

transpiration. However, moisture depletion on plots with catchment surfaces averaged slightly greater for shaded than unshaded trees, possibly due to stomata responding to humidity. On the south coast of Turkey, stomata of *Olea europaea* opened when moist air flowed in from the sea, even though water potentials were below the wilting point (Thomas M. Hinckley, Professor of Tree Physiology, College of Forest Resources, University of Washington, personal communication, March 1986). The combination of shade and catchment surfaces may have increased humidity enough to cause stomatal opening.

Interception of rainfall by the shade cloth would have caused effects opposite those observed: shade cloth covered approximately 93 percent of each shade-only plot (fig. 3) but only 70 to 75 percent of the combined plot and catchment surface area of each plot with both a ramada and catchment surfaces. Further, during the year that pressure-bomb measurements were taken, shade cloth was installed in late March when only about 25 percent of the season's rainfall was yet to fall.

In fall 1985, 5 years after planting, the two olive trees that escaped complete girdling were still in good condition, with no assistance except rodent control, initial watering, and a gravel mulch to reduce evaporation. The orange trees fared less well, even with catchment surfaces and shade. When plots were dismantled in late September 1985, however, orange tree survival and condition were somewhat better on plots with catchment surfaces than on plots without such surfaces.

petition from grass and weeds during the spring and summer prior to dismantling, which probably lowered the condition of trees and may have partly obscured treatment differences.

Whereas drought-tolerant species like olive may survive entirely on moisture stored in the soil, more water-demanding species obviously need some supplemental watering for good health and survival in climates similar to that in this study. Where soils are suitable, however, concentrating moisture and storing it in the soil should reduce the need for supplemental water for many species.

To be suitable, soils must be stable when saturated. In urban settings, soil is often a structural material as well as a medium for growing plants, and the load-bearing strength of soils usually decreases substantially when they are wet. Some soils even flow downhill when saturated! Extra soil moisture can threaten building foundations, roads, and other structures. Therefore, it would be prudent to work with a soils engineer before deciding to store runoff water in the soil around structures or on steep slopes.

In addition to stability when wet, soils need to have sufficient depth and moisture-holding capacity to store much of the extra water they are given. If soil stability and moisture storage capacity are suitable, then taking water from roofs, driveways, and other surfaces and spreading it across soils devoted to trees and other vegetation makes good sense and should greatly reduce the need for supplemental watering, especially if competing vegetation is eliminated and mulches are used to reduce evaporation.

Literature Cited

1. Waring, Richard H., and Brian D. Cleary. 1967. *Plant moisture stress: Evaluation by pressure bomb*. Science 155:1248-1254.

*Pacific Southwest Forest and Range Experiment Station
Forest Service, U.S. Department of Agriculture
P. O. Box 245, Berkeley, CA 94701*

Condition of trees	Number of trees	
	Catchment	No catchment
Good to excellent	3	0
Fair	4	3
Barely alive	4	5
Dead	1	4

Chi-square = 5.05 at 3 d.f., indicating approximately 80 percent likelihood of a relationship between treatment and condition. All plots had com-