

## SIX WAYS TO INCREASE OWNER'S RETURNS ON INVESTMENTS<sup>1</sup>

by W.R. Luckham

The professional commercial arborist is responsible for the survival of his firm in the short run, and for generating a profit in the longer run. The ultimate measure of the tree service firm's managerial effectiveness is commonly expressed as the percent return on assets (ROA) or the percent return on net worth (ROI). Return on assets measures the performance of the business without regard to its method of financing. Thus, reasonably valid comparisons can be made with other firms of similar size and type, and with other investment alternatives. Return on net worth or return on investment, on the other hand, measures performance of the business with special emphasis on its method of financing.

While the ultimate measure of managerial ability may be the return on either assets or net worth, the manager must concentrate his efforts on maintaining or increasing sales while at the same time controlling expenses and improving physical productivity. These inter-connected relationships may best be portrayed in the following model for strategic financial management. This model is divided into three major sections which produce the net profit margin, the asset turnover and the degree of leverage. The hypothetical firm "Acme Tree Service, Inc." discussed in the paper "Financial Ratio Analysis for Decision Making" will be used to illustrate this model.

The **margin management** section of the model focuses on the operating statement and illustrates the major factors responsible for generating the net profit and net profit margin. The **asset management** portion of the model highlights the key asset components and measures the number of times that the firm's assets are turned into sales each year — or asset turnover. Asset turnover when multiplied by the net profit margin yields the return on assets (ROA). The final section of the model, leverage,

deals with the debt and owners investment in the firm to compute the degree of leverage employed by Acme. The leverage factor, when multiplied by the ROA determines the return on net worth or owners investment (ROI). Note that leverage, as calculated by the model, is 1.0 higher than when typically determined. Typically, leverage is the relationship between debt and equity. In this case return on assets is multiplied by the leverage factor to determine the return on equity. Therefore, equity is added to debt to pick-up the earnings on equity before the total of debt plus equity (total assets) is divided by equity to determine the degree of leverage. Thus, the model illustrates how the firm works, from a financial standpoint. It provides insight to the manager as efforts are devoted to improve firm performance.

There are at least six major ways in which a manager can improve ROA or ROI. The model will help the manager decide upon which method or combination of methods to employ before taking action.

1. **Increase sales** without proportionately increasing expenses to achieve these sales. This is often difficult because the firm is typically generating all of the sales it can with its existing resources and economic climate. However, if resources are unused or underutilized, this option may be worth exploring. For example, if sales could be increased to \$10,000 by increasing the cost of goods sold by \$500 and variable expenses by only \$7,500, then \$2,000 would be added to net profit and the ROA increased to 6.4% and ROI to 17.8%  $[(\$181,000 + \$10,000) = \$191,000 - (\$10,500 + \$500) - (\$162,185 + \$7,500) = \$10,315 \text{ profit}; \$10,315 \div \$191,000 = .054 \times 100 = 5.40\% \text{ net profit margin}; 5.40\% \times (191,000 \div \$160,385) = 6.43 \text{ ROA}; 6.43 \times (\$160,385 \div \$57,835) =$

<sup>1</sup> Presented at the annual conference of the International Society of Arboriculture in Louisville, Kentucky in August 1982.

### TOTAL PROFITABILITY MODEL FOR STRATEGIC FINANCIAL MANAGEMENT

Acme Tree Service, Inc.  
1981

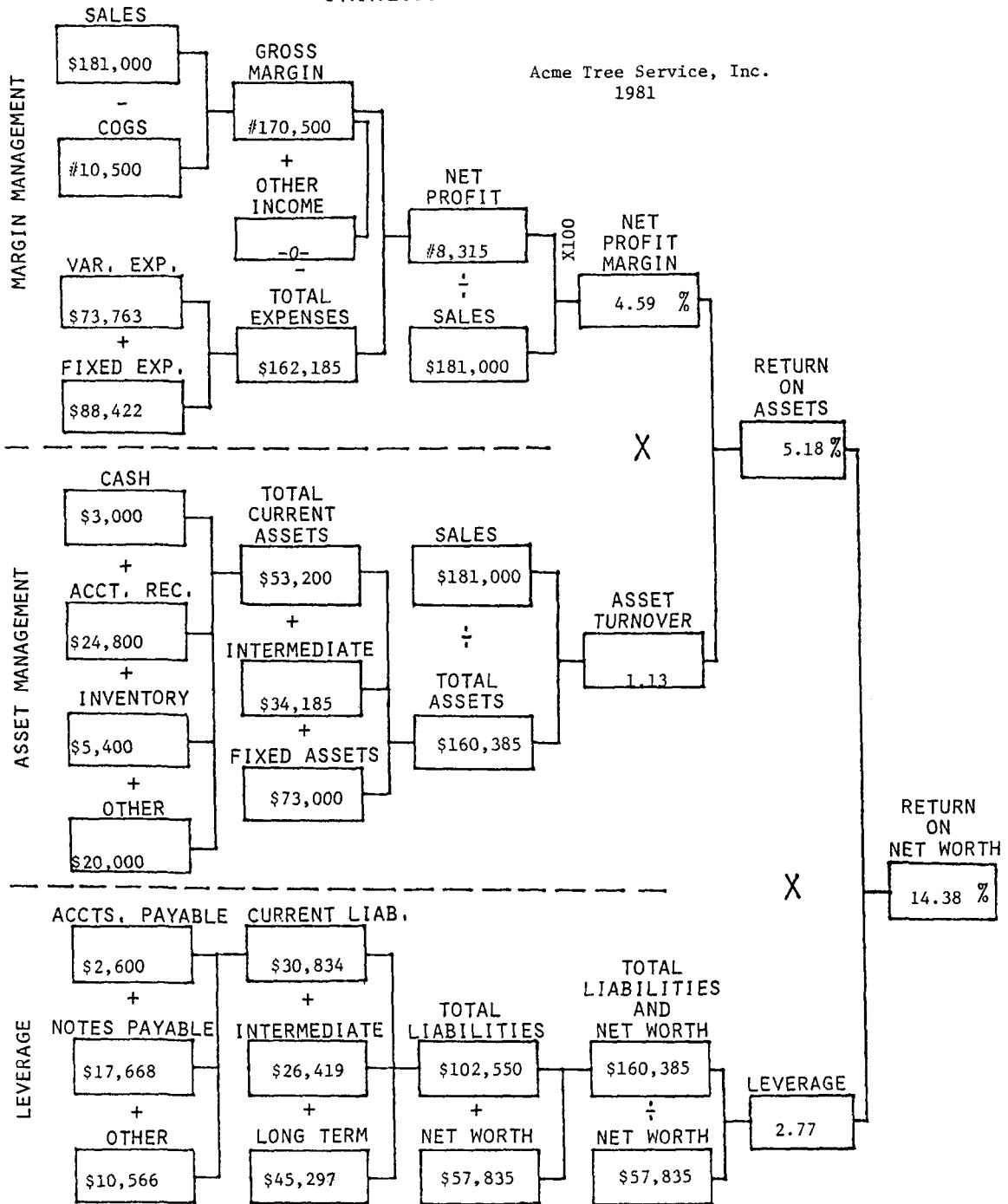

17.8% ROI]. This is a marginal increase for the effort required.

2. **Increase margins** by increasing prices, thus increasing total sales volume without a corresponding increase in expenses. In many cases, the competitive market situation will permit modest price increases or price differentials if values are perceived by customers. For example, 10% increase in margin will yield a sales volume of \$201,111. If 5% of Acmes sales are lost due to the price increase, volume will be \$191,055 and net profit increased to \$18,370 or a net profit margin of 9.62% and a ROA of 11.5% and a ROI of 31.8%. Note that as sales volume increases, asset turnover also increases. The resulting impact on ROA and ROI is dramatic. This is probably the easiest way to improve performance.
3. **Control expenses** without disproportionately affecting sales. Review of the mechanics portrayed in the model indicates that every \$1 saved through cost control translates into a dollar of added profit (provided current or longer term sales are not adversely affected). For example, if variable costs were decreased by \$2,000, net profit would increase to \$10,315 net profit margin to 5.7%, ROA to 6.4% and ROI 17.8%, or exactly equal to increasing sales by \$10,000 as illustrated in 1 above. Cost control is one of the most effective and longer lasting tools available to aggressive and effective managers.
4. Increase asset turnover by either increasing sales with the same total assets or by maintaining sales volume with fewer assets. Many firms have too much or too expensive equipment, too much or outdated inventory or excessive accounts receivable for the volume of business. Often buying used or leasing or renting infrequently used equipment or subcontracting specialized jobs not routinely done by the firm is a sound financial decision. These are a few of the factors which typically account for

low turnover of assets. Note that simply changing the form (accounts receivable to cash) in which assets are held will not change the asset turnover. Either assets must leave the business, or greater sales volume must be generated by the existing assets if the turnover rate is to be improved. For example, increasing the asset turnover to 1.5 by increasing sales would increase ROA to 6.9% and ROI to 19.1%. However, increasing the asset turnover by decreasing assets and similarly changing the degree of leverage, may not change the return on investment (ROI). The impact of proposal changes should be carefully evaluated before those changes are implemented.

5. Controlling inventory and accounts receivable are two important areas for many firms because they tie up working capital and may adversely affect the total assets employed by the firm. The net result is to affect asset turnover as discussed above.
6. Increase leverage by expanding the business through wise use of debt capital is an advantageous management strategy if the firm is generating returns significantly greater than the cost of capital. For example, if Acme were levered four times, the ROI would be increased to 20.7%.

Obviously, the more of these methods that can be appropriately implemented, the greater the total impact on ROA and ROI. While many managers do not like to spend time in the office or working with the financial data of the firm, there are few activities in which the manager could engage that would bring greater success. It is well worth while to become intimately acquainted with the financial workings of the firm. After all — it's management's job.

*Extension Economist in Agricultural Marketing  
Virginia Polytechnic Institute  
Blacksburg, Virginia*